

SERIES 08-02



Precision Snap Disc Thermostats Surface Mounting Type

FEATURES

- Ratings to 12A at 240 VAC
- 100,000 Cycle Rating
- UL Component Recognized
- CSA Certified 
- CE Compliant 
- Tamper-Proof Preset Temperature
- Calibrated Settings from 35 to 350°F (2 to 176°C)
- Automatic Reset
- Vibration Resistant



APPLICATIONS

- Power Supplies
- Solar Heating
- Copiers
- Communications Equipment
- Refrigeration Compressors
- Welding Equipment
- Food Processing

DESCRIPTION

A snap-acting disc serves as the actuating element in these rugged, precision thermostats. As the temperature reaches the tamper-proof predetermined set point, the disc snaps to provide rapid, positive contact action minimizing radio frequency interference and ensuring high reliability.

These thermostats are individually calibrated and tested to meet both thermal and electrical characteristics. The single contact switch arm assembly minimizes failures due to contact contamination, while the fine silver contacts assure long life and excellent current carrying capacity. Resistance to vibration and harsh environments are additional features.

The ceramic base and metal cap provide protection from contamination and an optional epoxy seal improves resistance to harsh environments.

Many terminations and mounting assemblies are available to permit great flexibility in installation. Thermostats feature current carrying capacities up to 12A at 240VAC measuring .350" in height. An optional epoxy seal provides additional protection against contamination.

TEST SAMPLES

Operating samples can be supplied for application tests. A completed Fenwal Snap Disc Application Data Form is required to select and produce an operating sample. Application Data Forms are available at www.fenwalcontrols.com or your local Fenwal sales representative.

The following model is normally available from stock.

Normally Closed Contacts - Open on Rise				
Part Number	Mounting	Terminals	Opens °F	Close °F
08-023384-463	B2, H4	T7	140	120

SPECIFICATIONS

Switch Action

SPST (normally open or normally closed)

Dielectric Strength

1500 VAC terminals to case.

Insulation Resistance

100 Megohms minimum 500VDC.

Vibration

MIL-STD-202D, Method 204B, 10 G's.

Shock



MIL-STD-213B, Test Condition K, 30 G's, 11 millisc.

RANGED AND TOLERANCE - TABLE 1

Series	Temp Range	Tolerances		Differential (Nominals)
		Open	Closed	
08-02	35 to 240°F	±7°F ±4°C	±8°F ±4°C	20°F 11°C
	241 to 300°F 116 to 148°C	±7°F ±4°C	±8°F ±4.5°C	25°F 14°C
	301 to 350°F 149 to 177°C	±8°F ±4.5°C	±10°F ±6°C	30°F 17°C

Note: Differences in temperature testing procedures and equipment, between those of the manufacturer and the customer, can result in temperature variances of up to 2°F.

ELECTRICAL RATINGS - RESISTIVE TABLE 2

Series 08-02				
120VAC	240VAC	30VDC	Cycles	Approvals
12A 120VA	12A 120VA	2A	100,000 100,000	 



 and  units rated for AC operation only
 U.L. File E18974, Guide XAPX2
 C.S.A. File LR 7378, Class 4823 02 
 Certified by BG Technology

TABLE 3

Mounting Bracket Stainless Steel	Mounting Hardware Size
B1 - No Bracket (Cap Only)	H1 - No hardware (use B1)
B2 - Bottom Oval Flange	H4 - #6 screw for flange mounting
B6 - Stud Mounting Screw	H6 - #6 screw for stud mounting
Lead Wires Specify length	
L1 - No Lead Wires	L2 - 105°C PVC, 18 AWG, 300V insulation
L3 - 200°C TFE, 18 AWG, 300 V insulation	L4 - 250°C TGGT, 18 AWG, 300V insulation
Terminals Positions	
T1 - Eyelet, opposed horizontal	T2 - Eyelet, opposed vertical
T3 - eyelet, parallel horizontal	T4 - Eyelet, parallel horizontal, reverse step
T6 - 1/4" Quick Connect, opposed horizontal	T7 - 1/4" Quick Connect, opposed vertical
T10 - Leads, opposed horizontal	T11 - Leads, opposed vertical
T12 - Leads, parallel horizontal	T13 - Leads, parallel vertical
T14 - Vertical lead wires with epoxy filled mylar sleeve	

TERMINALS AND POSITIONS

OUTLINE DIMENSION

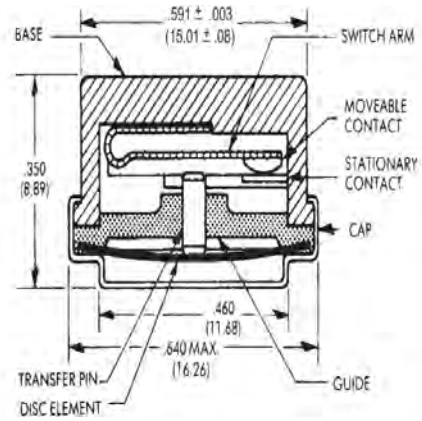
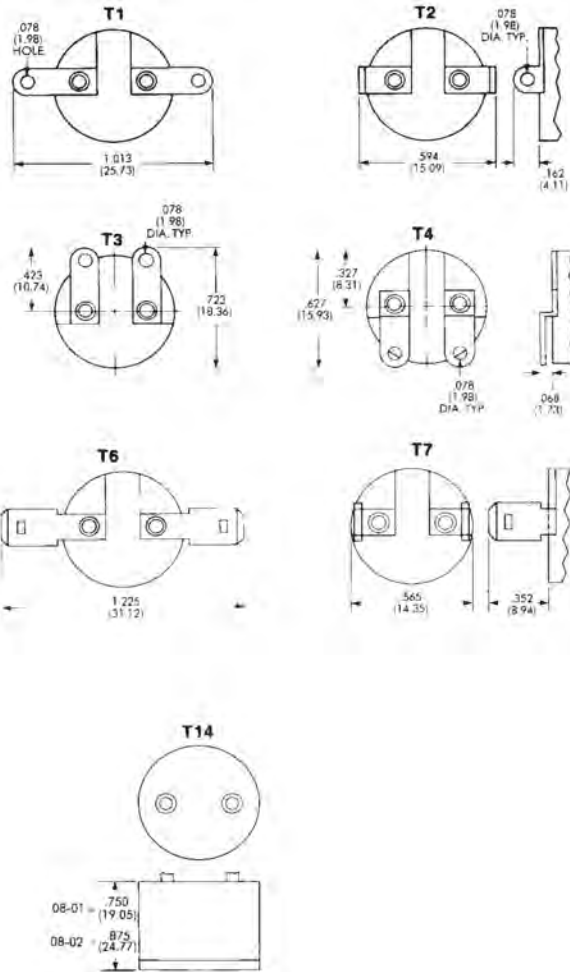

MOUNTING BRACKETS

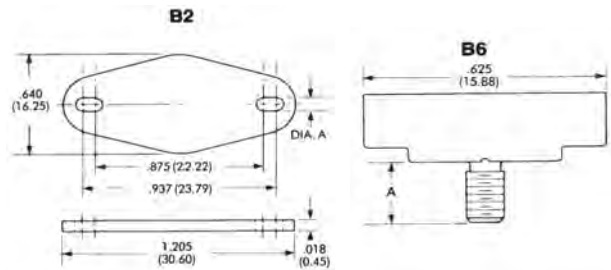

Hardware Size	Dim. A
H4	.143 (3.63)

Hardware Size	Dim. A
H6	6-32 x 3/8"

Note: Dimensions in brackets are millimeters. Specifications are subject to change without notice.

HOW TO ORDER

To more clearly define specific requirements, please complete a Fenwal Snap Disc Application Data Form, available at www.fenwalcontrols.com or your local Fenwal sales representative.

To order:

1. Select Series Number desired from Table 1 on Page 2. Specify Series 08-81.
2. Specify opening and closing temperatures in degrees Fahrenheit or Celsius with tolerance, and whether the switch action should open or close on temperature rise.
3. Specify terminals and mounting configurations by selecting one code number from each category in Table 3. If lead wires are required, specify length.

EXAMPLE: 08-02, open at 175°F, close at 155°F, B2, C3, H4, T1, L1 = Series 08-02 thermostat set to open at 175°F±7°F on temperature rise, close at 155°F±7°F on temperature drop. Bottom oval flange mounting bracket; holes to accept #6 mounting hardware (not supplied); eyelets, opposed horizontal; no lead wires.

This literature is provided for informational purposes only. KIDDE-FENWAL, INC. assumes no responsibility for the product's suitability for a particular application. The product must be properly applied to work correctly. If you need more information on this product, or have a particular problem or question, contact KIDDE-FENWAL, INC.

**FENWAL
CONTROLS**

F-08-02-001 Rev AA