

Fire Suppression Systems

Low Pressure CO₂ Storage Tanks

Effective: December 2019
K-64-001 Rev AA

FEATURES

- Factory Mutual (FM) Approved
- 2.75T to 60T Range
- Horizontal and Vertical Units
- R-404A Refrigerant
- Optional Dual Safety Relief Valve Sets
- High Quality Steel Construction
- Aluminum Outer Jacket Construction
- Forged Steel Fittings
- Polyurethane Insulation

DESCRIPTION

CARDOX[®] Bulk Low Pressure Carbon Dioxide Storage Units are available in models with storage ranges from 2.75 U.S. tons to 60 U.S. tons of liquid Carbon Dioxide. These storage units incorporate design, construction and testing in accordance with ASME (American Society of Mechanical Engineers) Boiler & Pressure Vessel Code, Section VIII, Division 1, Pressure Vessels.

These storage units (horizontal or vertical) provide a compact suppression system footprint protecting facilities.

A 4-in, minimum, thick polyurethane layer sheathed inside an aluminum outer jacket insulates the steel pressure vessel. A factory fitted low-temp air-cooled, providing maximum reliability, refrigeration package chills the CO₂ to approximately 0F (-17C) at 300-psi (20.6 bar). The refrigeration package is available in a variety of voltages, which offers global compatibility with local power requirements.

The insulation scheme and refrigeration package provides efficient continuous duty operation, affording reduced facility overhead.

As a standard factory configuration, each storage unit arrives at the project site outfitted with a single safety relief valve set and dual 6-in diameter gauges for pressure and liquid level indication.

The storage units are built to comply with stringent industrial standards and are certified by Factory Mutual

CARDOX Low Pressure Carbon Dioxide Storage Units offer a wide range of storage capacities, refrigeration options, temperature ranges in lightweight construction.

AVAILABLE REFRIGERATION PACKAGE VOLTAGES

- 1 = 120V/60Hz/1-Phase
- 2 = 220V/60Hz/1-Phase
- 3 = 220V/50Hz/1-Phase
- 4 = 220V/60Hz/3-Phase
- 5 = 380V/50Hz/3-Phase
- 6 = 460V/60Hz/3-Phase
- 7 = 575V/60Hz/3-Phase

Number 1-7 range applies to the Storage Unit Stock Number "X" Placeholder. Reference the CARDOX LPCO₂ Storage Unit manual for specific voltages applicable to each LPCO₂ storage unit.

ADDITIONAL OUTFITTING OPTIONS AVAILABLE AS SHOWN BELOW:

- Liquid Level Gauge with Dual (NO/NC) Contacts
- Liquid Level Gauge with 4-20mA Output Signal
- Cold Weather Instrumentation Package
- Canadian Standards Association (CSA) Approval
- Pressurized Equipment Directive (PED) Approval
- Redundant Safety Relief Valve Set
- Heavy Wall Pressure Vessel

TECHNICAL SPECIFICATIONS

Material:	SA-612 normalized CS
MAWP:	350 psig (24.1 bar)
MDMT:	-40 °F (-40 °C)
Operational Temperature	
Minimum:	-10°F (-23.3°C)
Maximum:	130°F (54.4°C)
Piping:	Sch 80 seamless
Fittings:	2000lb. forged fittings
Valve type:	Ball type
Insulation:	
Horizontal tanks:	4 in. polyurethane
Vertical tanks:	6 in. polyurethane
Refrigerant:	R-404A
Instrumentation:	
Liquid Level:	6 in. (152.4 mm) dial gauge
Pressure:	6 in. (152.4 mm) dial gauge
Audible Alarm:	High/Low Pressure

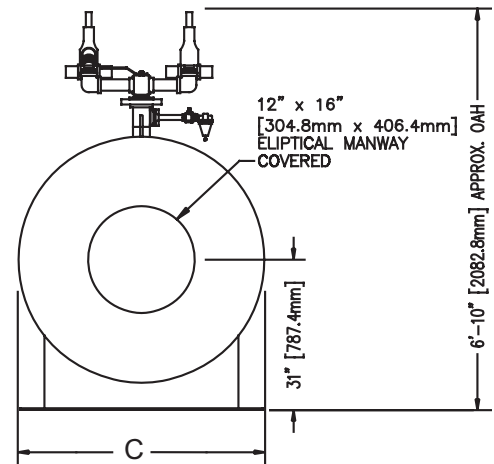
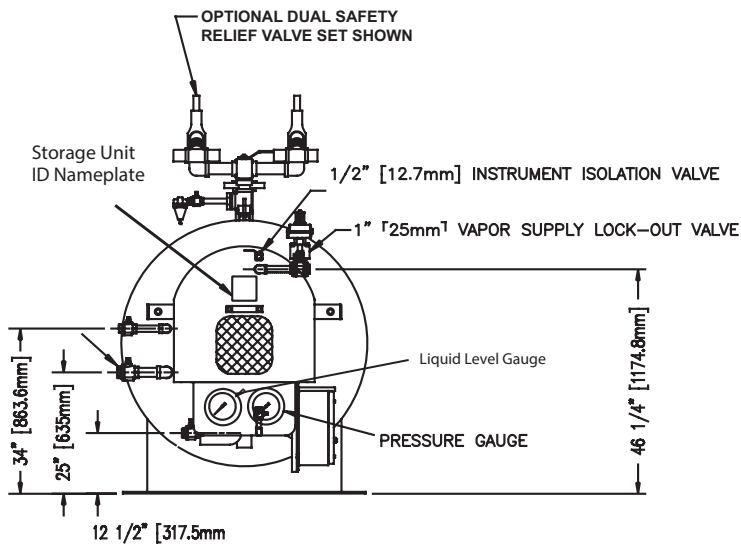
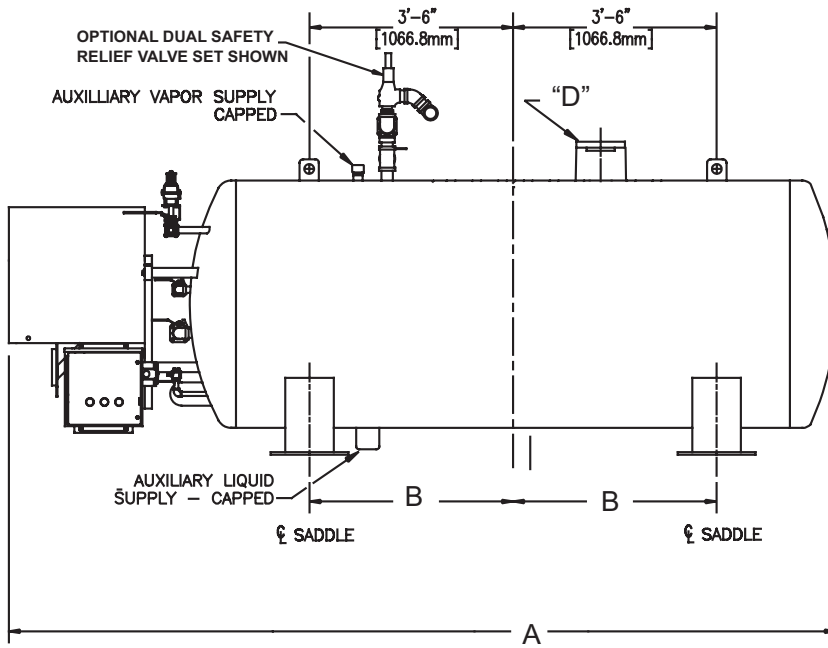

Figure 1: 2 3/4 Ton Tank

Table 1. 2 3/4 Ton Tank Specifications

Size (Tons)	Part Number	A** *Allow 4ft. 0in. (1219.2mm) for Open Door Clearance	B	C	D	Weight (Empty)
2 3/4	7048H02X	14 ft. 5 in. (4381mm)	3 ft. 6 in. (1066.8mm)	4 ft. 3 in. (1295mm)	4 in. (101mm)	4,000 lb. (1814kg)

**Add 9 in. (228.6mm) for 3 phase refrigeration units (2 3/4 ton model only)

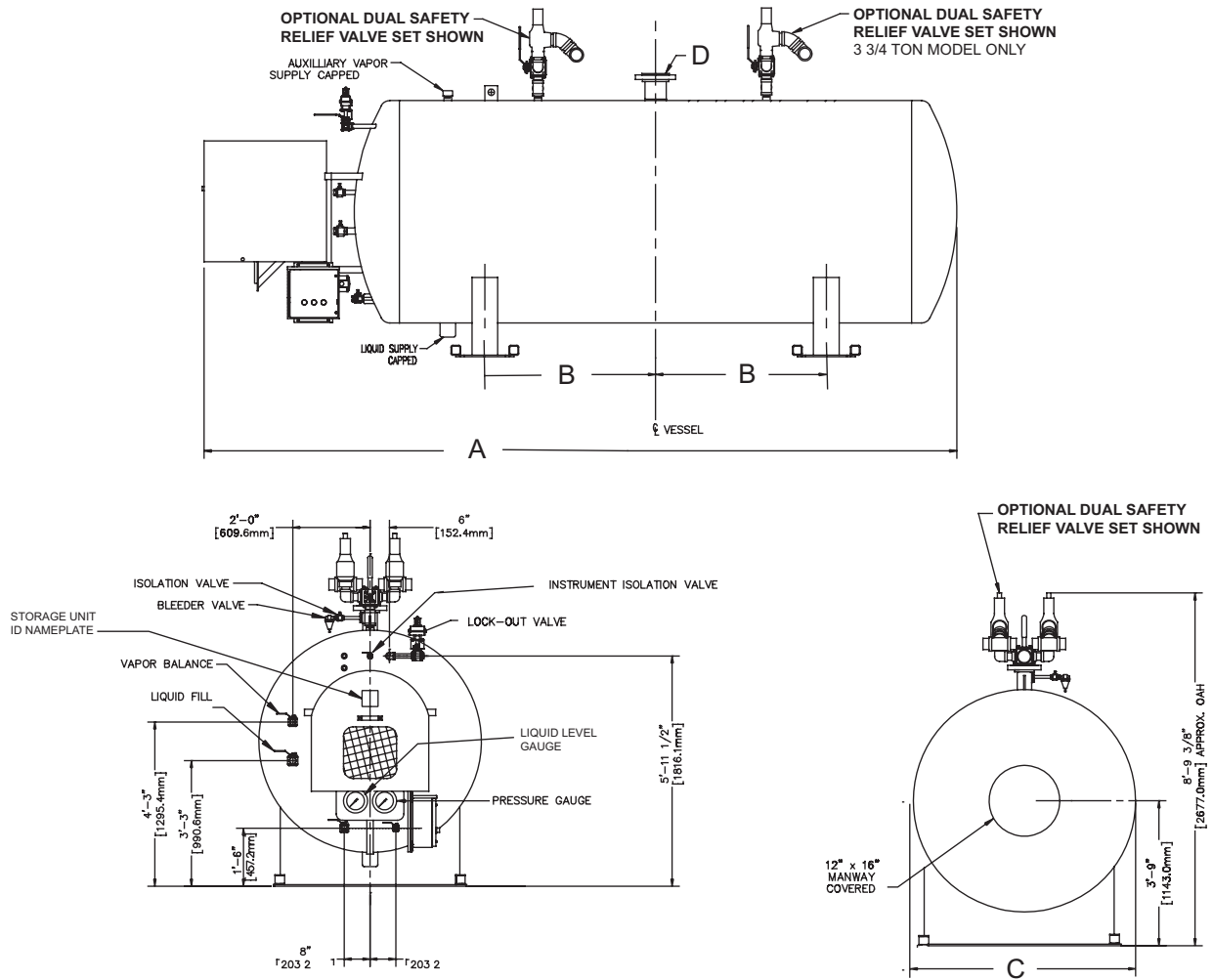

Figure 2: 3 3/4 through 12 Ton Tanks

Table 2. 3 3/4 through 12 Ton Tanks Specifications

Size (Tons)	Part Number	A *Allow 4ft. 0in. (1219.2mm) for Open Door Clearance	B	C	D	Weight Empty
3 3/4	7048H03X	11 ft. 10 in. (3606.8 mm)	1 ft. 8 in. (501.6 mm)	5 ft. 9 in. (1754.1 mm)	6 in. (152.4 mm)	7,500 lb. (3,402 kg)
4	7048H04X	12 ft. 10in. (3912 mm)	1 ft. 11.5 in. (596.9 mm)	5 ft. 9 in. (1754.1 mm)	6 in. (152.4 mm)	7,730 lb. (3,507 kg)
6	7048H06X 7148H06X	15 ft. 6 in. (4724.4 mm)	2 ft. 8 in. (812.8 mm)	5 ft. 9 in. (1754.1 mm)	6 in. (152.4 mm)	9,000 lb. (3,359 kg)
8	7048H08X 7148H08X	19 ft. 6 in. (5943.6 mm)	4 ft. 5 in. (1346.2 mm)	5 ft. 9 in. (1754.1 mm)	6 in. (152.4 mm)	10,200 lb. (4,627 kg)
10	7048H10X	23 ft. 4 in. (7112 mm)	6 ft. 3 in. (1892.3 mm)	5 ft. 9 in. (1754.1 mm)	8 in. (203.2 mm)	11,500 lb. (5,216 kg)
12	7048H12X	26 ft. 2 in. (7975.6 mm)	7 ft. 9 in. (2362.2 mm)	5 ft. 9 in. (1754.1 mm)	8 in. (203.2 mm)	12,650 lb. (5,738 kg)

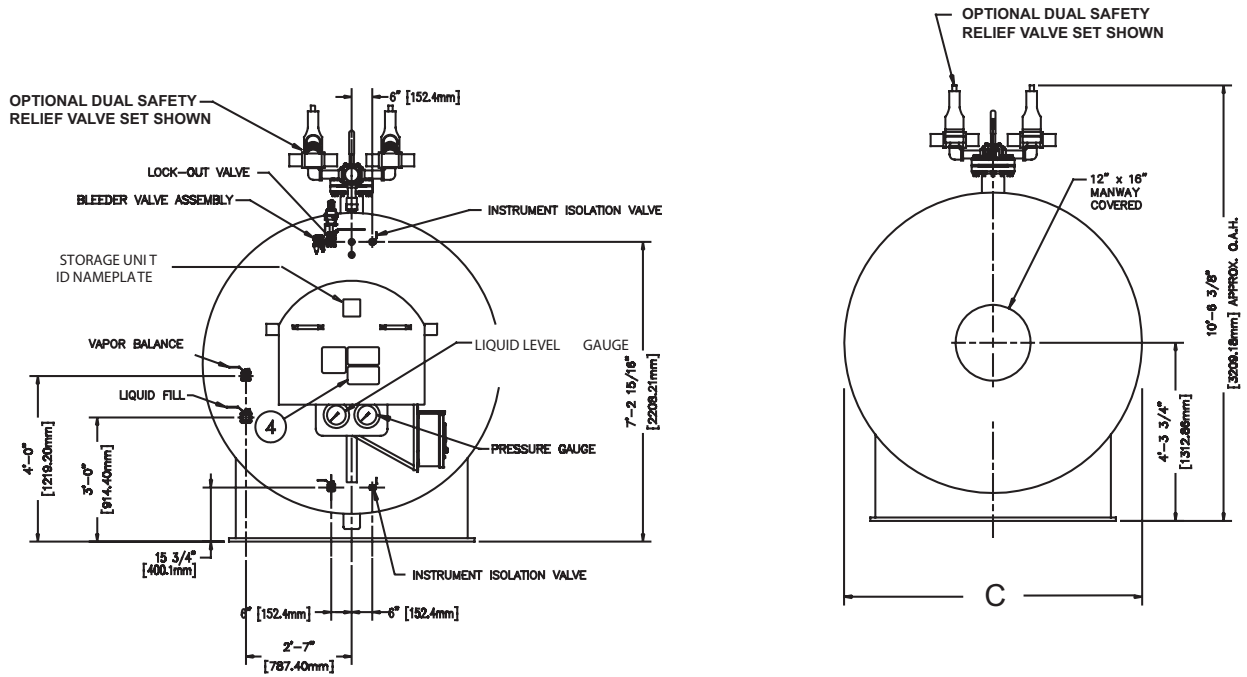
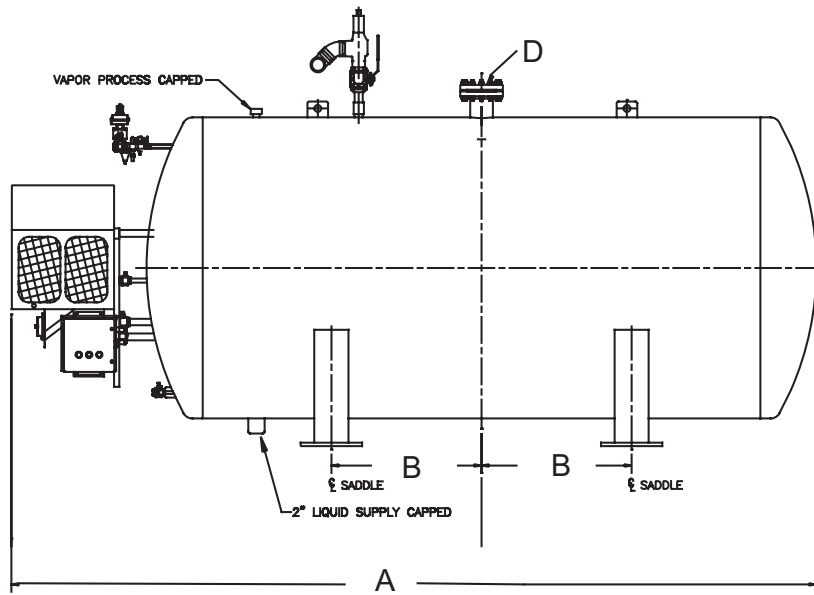

Figure 3: 14 Ton Tank

Table 3. 14 Ton Tank Specifications

Size (Tons)	Part Number	A *Add 4ft. 0in. (1219.2mm) for Open Door Clearance	B	C	D	Weight (Empty)
14	7048H14X	19 ft. 8 in. (5994.4 mm)	3 ft. 8 in. (1117.6 mm)	7 ft. 4 in. (2235.2 mm)	8 in. (203.2 mm)	14,000 lb. (6350.3 kg)

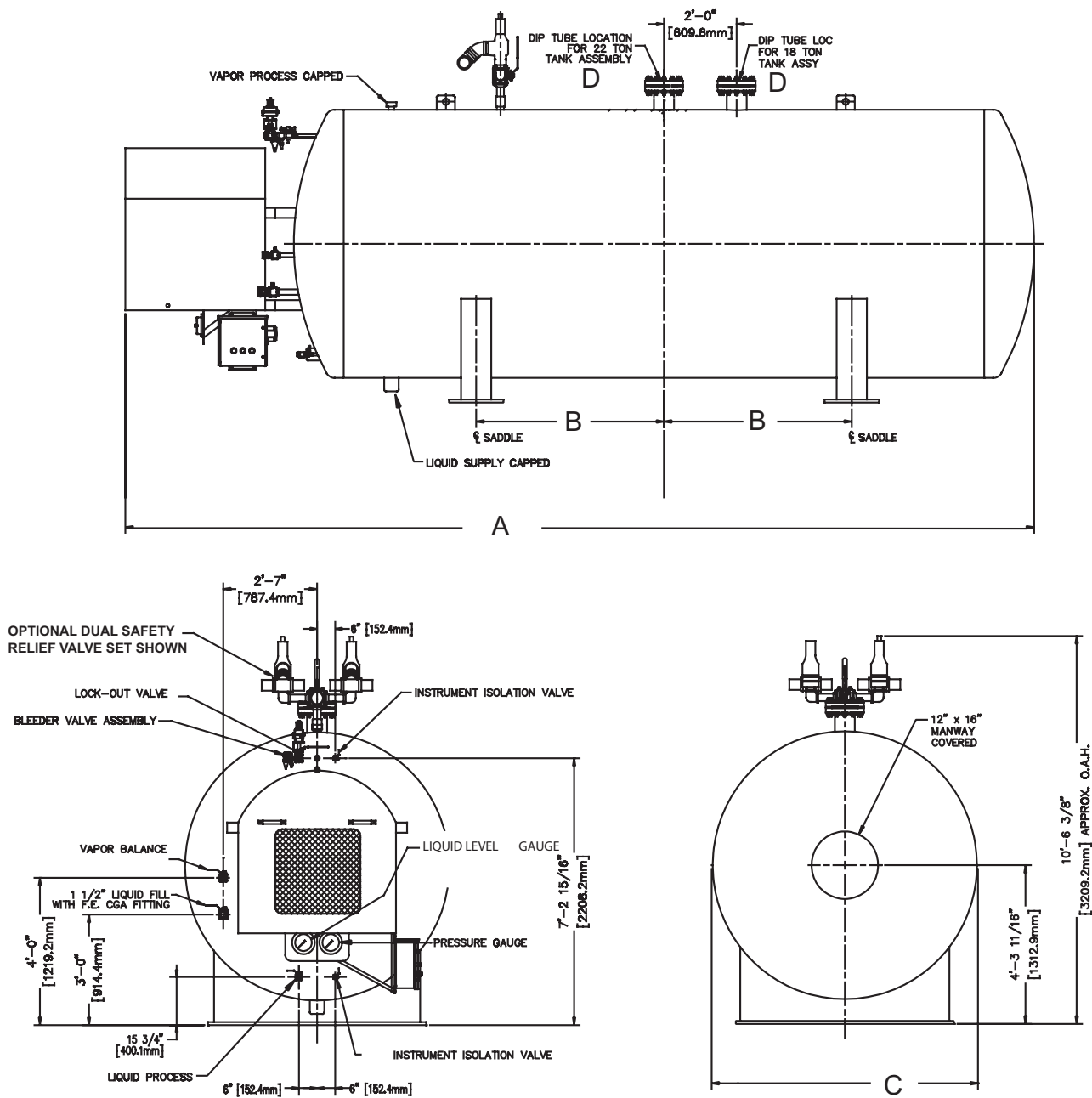

Figure 4: 18 and 22 Ton Tanks

Table 4. 18 and 22 Ton Tank Specifications

Size (Tons)	Part Number	A *Allow 4ft. 0in. (1219.2mm) for Open Door Clearance	B	C	D	Weight (Empty)
18	7048H18X	25 ft. 0 in. (7620.0 mm)	5 ft. 2 in. (1574.8 mm)	7 ft. 4 in. (2234.4 mm)	8 in. (203.2 mm)	16,800 lb. (7,620 kg)
22	7048H22X	29 ft. 4 in. (8940.8 mm)	7 ft. 0 in. (2133.6 mm)	7 ft. 4 in. (2234.4 mm)	8 in. (203.2 mm)	19,000 lb. (8,618 kg)

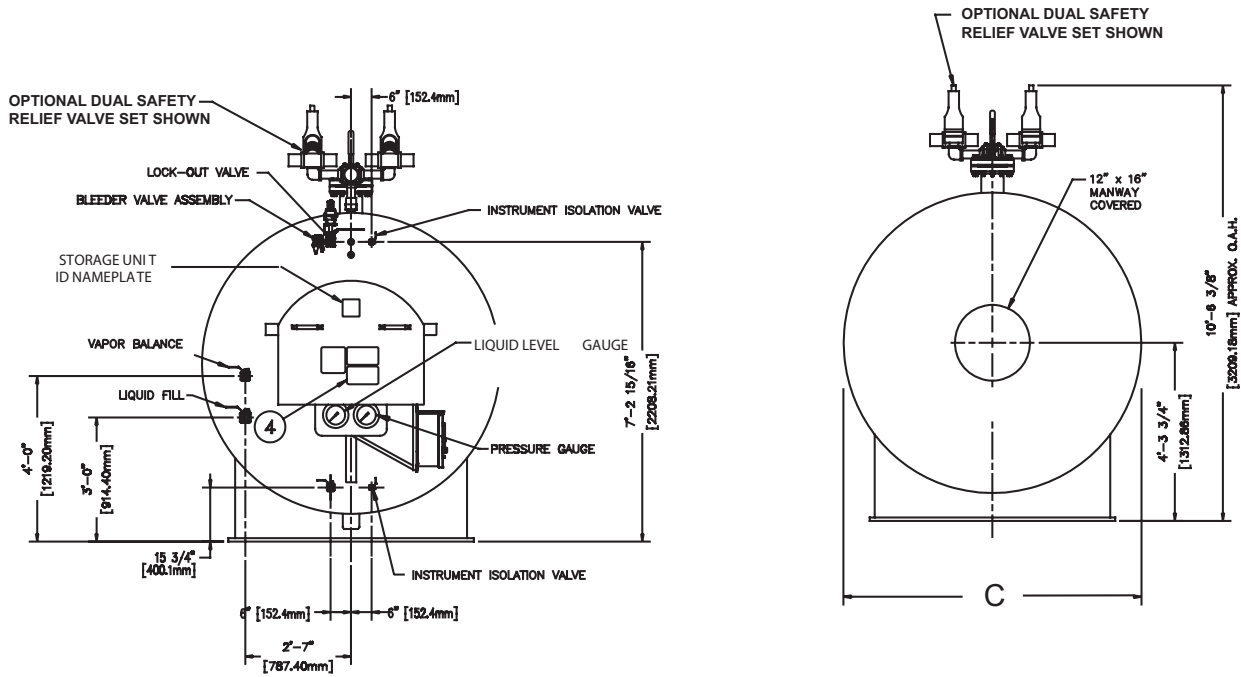
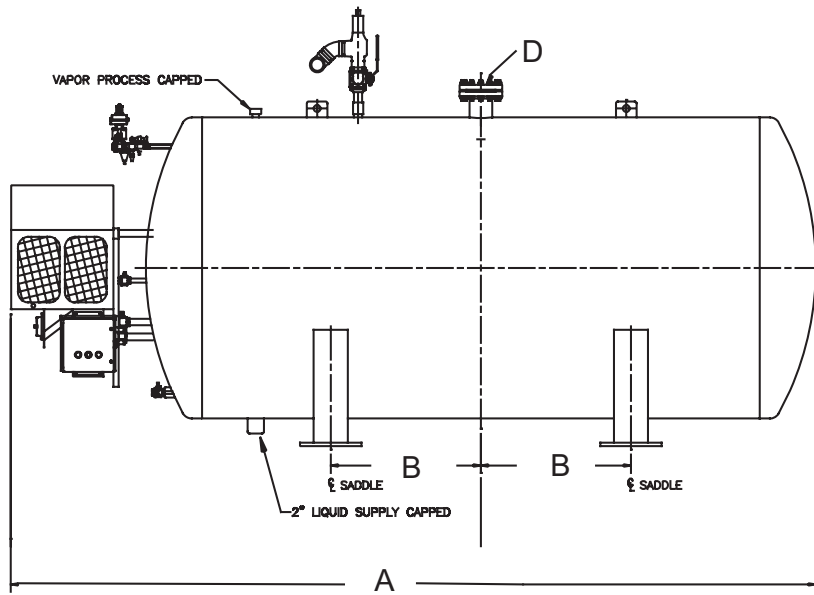

Figure 5: 26 Ton Tank

Table 5. 26 Ton Tank Specifications

Size (Tons)	Part Number	A *Allow 4ft. 0in. (1219.2mm) for Open Door Clearance	B	C	D	Weight (Empty)
26	7048H26X	32 ft. 8 in. (9953.4 mm)	9 ft. 0 in. (2743.2 mm)	7 ft. 4 in. (2234.4 mm)	8 in. (203.2 mm)	23,500 lb. (10,659 kg)

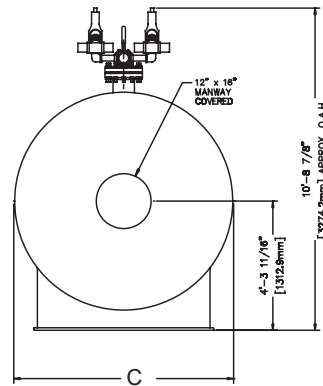
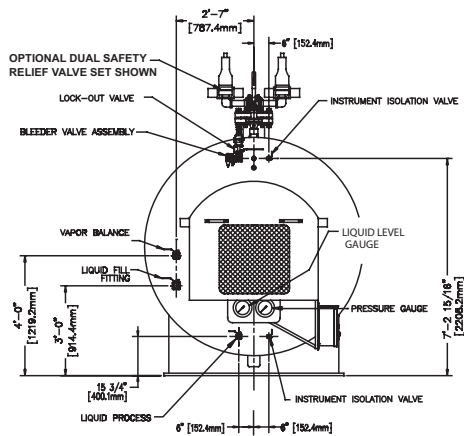
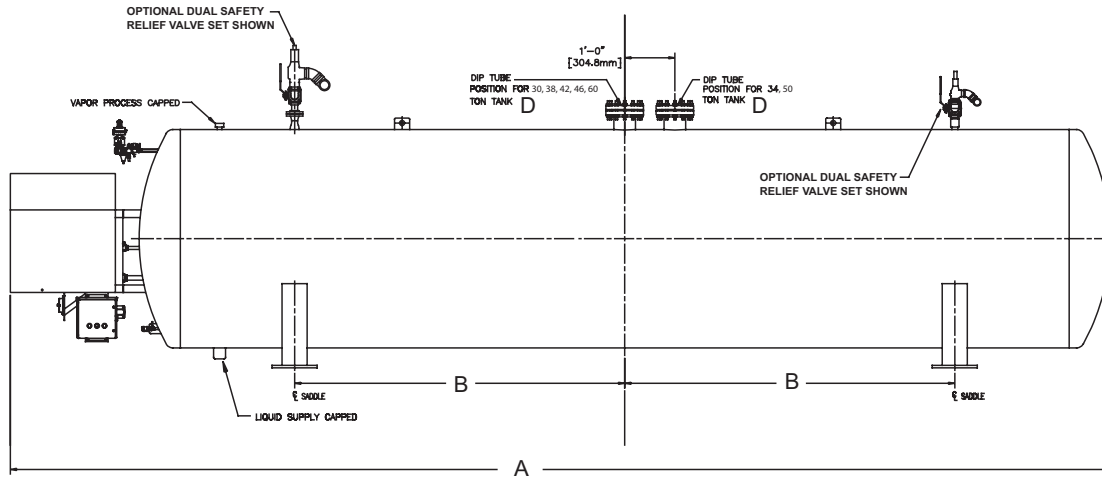

Figure 6: 30 through 60 Ton Tanks

Table 6. 30 through 60 Ton Tank Specifications

Size (Tons)	Part Number	A *Allow 4ft. 0in. (1219.2mm) for Open Door Clearance	B	C	D	Weight Empty
30	7048H30X	36 ft. 8 in. (11172.6 mm)	11 ft. 0 in. (3352.8 mm)	7 ft. 4 in. (2234.4 mm)	8 in. (203.2 mm)	26,500 lb. (12,020 kg)
34	7048H34X	40 ft. 8 in. (12391.8 mm)	13 ft. 0 in. (3962.4 mm)	7 ft. 4 in. (2234.4 mm)	8 in. (203.2 mm)	29,000 lb. (13,154 kg)
38	7048H38X	44 ft. 8 in. (13611.2 mm)	15 ft. 0 in. (4572.0 mm)	7 ft. 4 in. (2234.4 mm)	8 in. (203.2 mm)	31,500 lb. (14288 kg)
42	7048H42X	48 ft. 8 in. (14830.4 mm)	17 ft. 0 in. (5181.6 mm)	7 ft. 4 in. (2234.4 mm)	8 in. (203.2 mm)	34,000 lb. (15,422 kg)
46	7048H46X	52 ft. 8 in. (16049.6 mm)	19 ft. 0 in. (5791.2 mm)	7 ft. 4 in. (2234.4 mm)	8 in. (203.2 mm)	36,500 lb. (16,556 kg)
50	7048H50X	56 ft. 8 in. (17268.8 mm)	19 ft. 0 in. (5791.2 mm)	7 ft. 4 in. (2234.4 mm)	8 in. (203.2 mm)	40,000 lb. (18,143 kg)
60	7048H60X	66 ft. 8 in. (20316.8 mm)	24 ft. 0 in. (7315.2mm)	7 ft. 4 in. (2234.4 mm)	8 in. (203.2 mm)	45,000 lb. (20,411 kg)

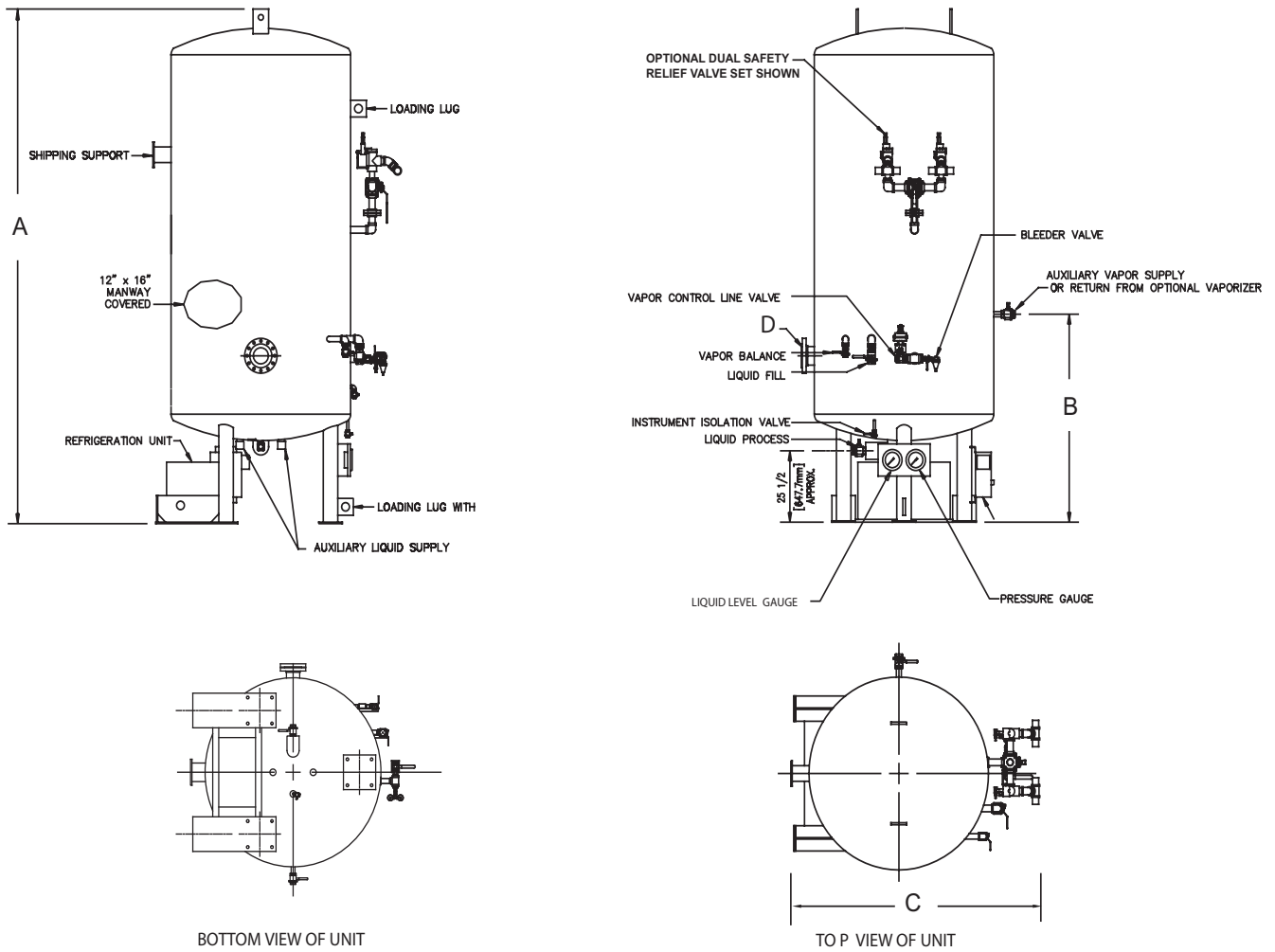

Figure 7: 6 Ton Tank

Table 7. 6 Ton Tank Specifications

Size (Tons)	Part Number	A	B	C	D	Weight (Empty)
6	7048V06X	15 ft. 3 in. (4648.2 mm)	6 ft. 3 in. (1889.1 mm)	7 ft. 11 in. (2400.3 mm)	6 in. (152.4 mm)	10,000 lb. (4,535 kg)

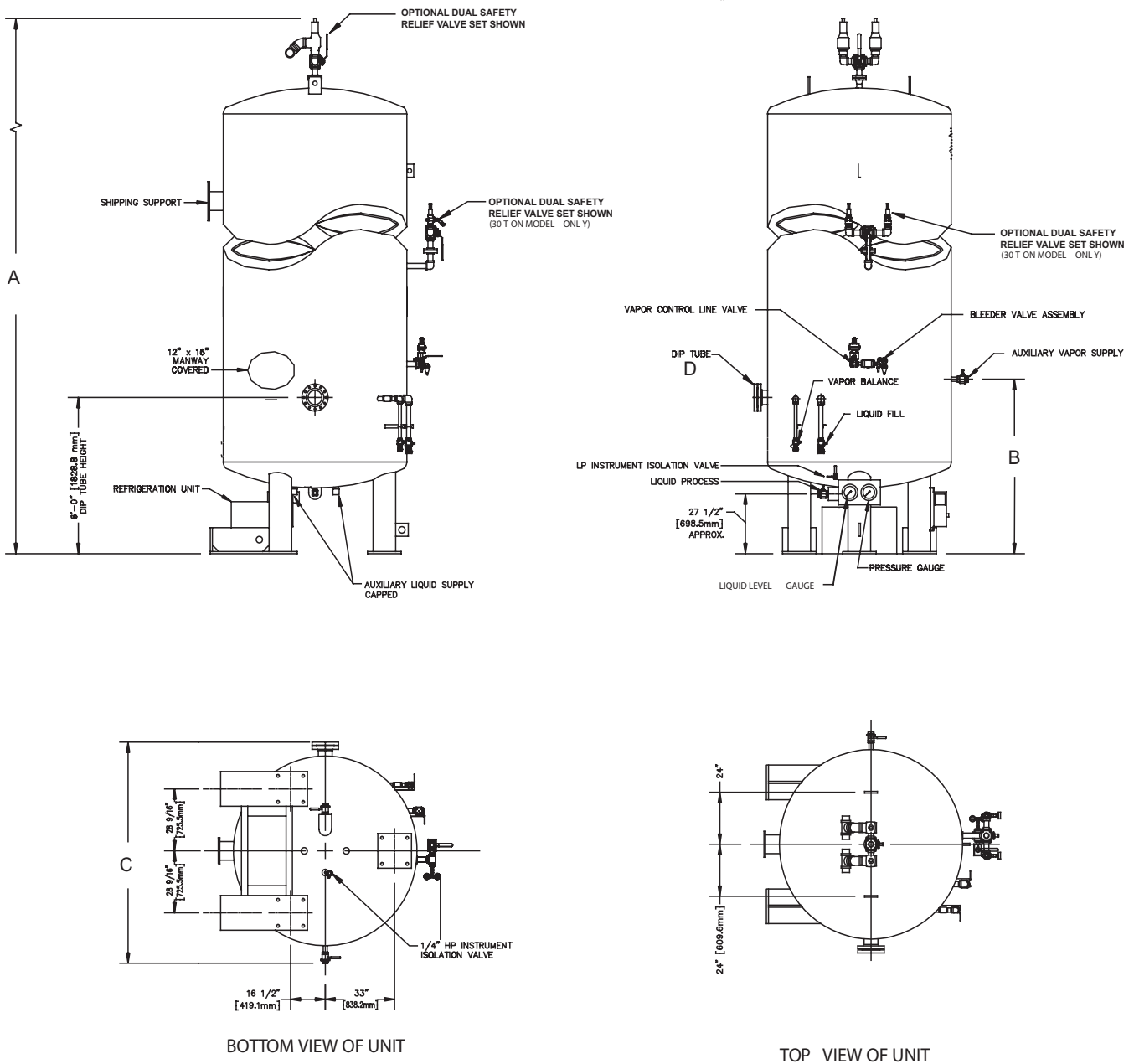

Figure 8: 14, 26, and 30 Ton Tanks

Table 8. 14, 26, and 30 Ton Tank Specifications

Size (Tons)	Part Number	A	B	C	D	Weight (Empty)
14	7048V14X	22 ft. 4 in. (6807.2mm)	6 ft. 7 in. (1993.9 mm)	8 ft. 9 in. (2667 mm)	6 in. (152.4 mm)	15,500 lb. (7,030 kg)
26	7048V26X	33 ft. 8 in. (10261.6 mm)	6 ft. 7 in. (1993.9 mm)	8 ft. 9 in. (2667 mm)	6 in. (152.4 mm)	25,000 lb. (11,339 kg)
30	7048V30X	37 ft. 5 in. (11404.6 mm)	6 ft. 7 in. (1993.9mm)	8 ft. 9 in. (2667 mm)	6 in. (152.4 mm)	30,000 lb. (13,607 kg)

EXPORT INFORMATION (USA)

Jurisdiction: EAR

Classification: EAR99

This document contains technical data subject to the EAR.

Cardox is a registered trademark of Kidde-Fenwal, Inc., or its parents, subsidiaries, or affiliates.
All trademarks are the property of their respective owners.

This literature is provided for informational purposes only. KIDDE-FENWAL, INC. believes this data to be accurate, but it is published and presented without any guarantee or warranty whatsoever. KIDDE-FENWAL, INC. assumes no responsibility for the product's suitability for a particular application. The fire suppression system design, installation, maintenance, service and troubleshooting must be performed by trained, authorized Kidde Fire Systems distributors for the product to work correctly. If you need more information on this product, or if you have a particular problem or question, contact: KIDDE-FENWAL, INC., Ashland, MA 01721 USA, Telephone: (508) 881-2000.